

ITEM	ITEM QTY	PART No	DESCRIPTION	REV	MASS
1	2	RT-A002	MASTER ROD ASSY	A	1.274 KG
2	10	RT-A003	PISTON ASSY	A	0.385 KG
3	1	RT-A004	FRONT BLOCK ASSY	A	17.851 KG
4	1	RT-A005	REAR BLOCK ASSY	A	21.077 KG
5	1	RT-A008	HEAD ASSY	A	56.179 KG
6	1	RT-A010	CRANK-SHAFT ASSY	A	12.525 KG
7	1	RT-A015	FRONT COVER ASSY	A	7.841 KG
8	1	RT-A016	REAR COVER ASSY	A	13.152 KG
9	1	RT-A017	TIMING SHAFT ASSY	A	2.509 KG
10	8	RT-C002	CONROD	A	0.153 KG

REV # = PURCHASED PART

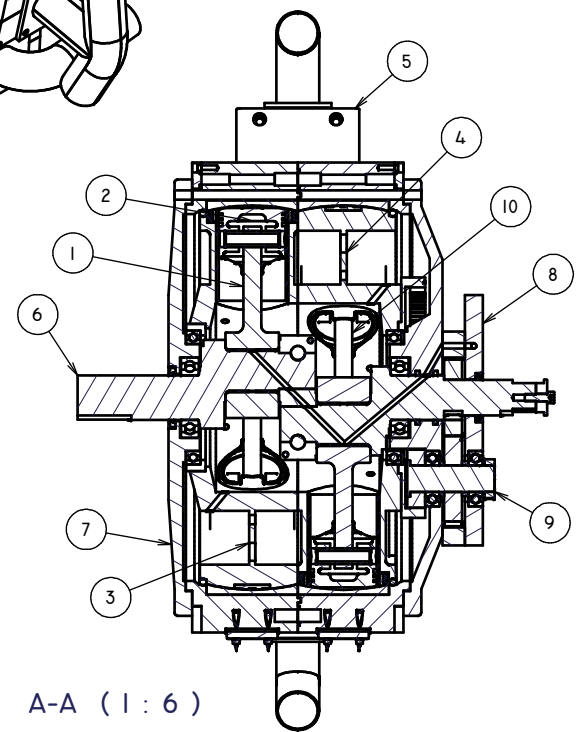

A-A (1:6)

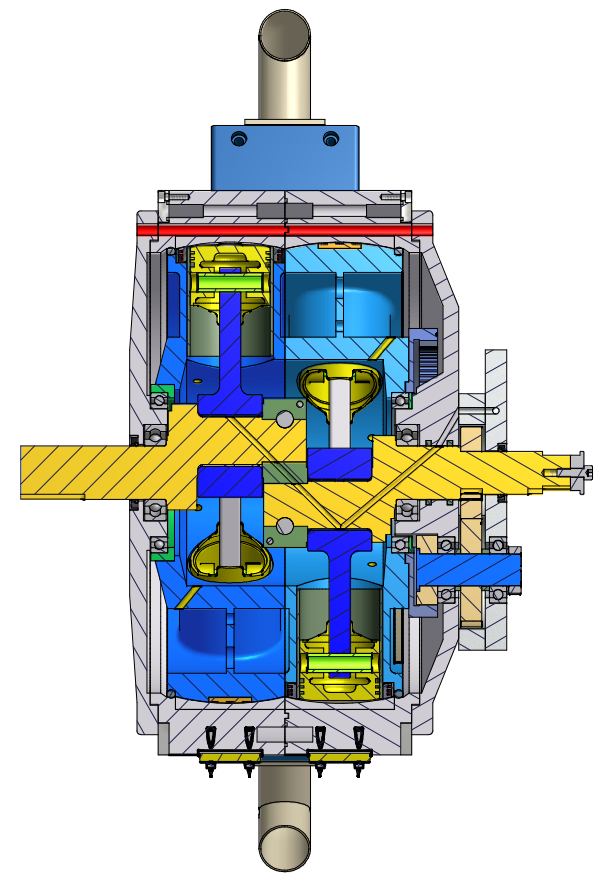

B-B (1:5)

This drawing and all information thereon is the property of the customer and is confidential and must not be made public or copied. Reproduction in whole or in part, or disclosure of information from the drawing to third parties requires the prior consent of the customer. All rights conferred by the law of copyright and by virtue of international copyright conventions are reserved by the customer.

	APPROVED BY:	DATE:	DRN BY:	SCALE:	CUSTOMER:		
	-	10/04/2007	NHW	1:6	customer		
ALL DIMENSION IN MILLIMETRES U.N.O. * DIMENSION TOLERANCES U.N.O. SHALL BE: MACHINING - UP TO 300mm ±0.1 > 300 TO 1000mm ±0.25 > 1000mm ± 0.5 ~ ALL ANGLES ±1 * FOR BASIC FABRICATION ±1.0mm U.N.O. * REMOVE ALL SHARP CORNERS, BURRS.						PART DESCRIPTION: MOTOR ASSEMBLY	A3
DWG NUMBER: -RT-A001				Revision A	Sheet 1 / 1		